

Hobie® Mirage® Pro Angler
H-Rail Upgrade Kit



1. 4X Tall End Fitting
2. 2X H-Rail
3. 2X Steering Handle Mount
4. 2X H-Rail Mount Base
5. 2X Backing Plate
6. 2X PA H-Rail Steering Crank
7. 4X Screws 10-32 x 1-3/8"
8. 4X Nuts 10-32 Nylock
9. 2X Screw 1/4"x1"
10. 2X Screw 1/4"x1-1/2"
11. Poly Rope

Tools needed:

- 1/8" Allen® key
- 1/4" Allen key
- #2 Phillips® screwdriver
- #3 Phillips screwdriver
- Drill
- 1/4" drill bit

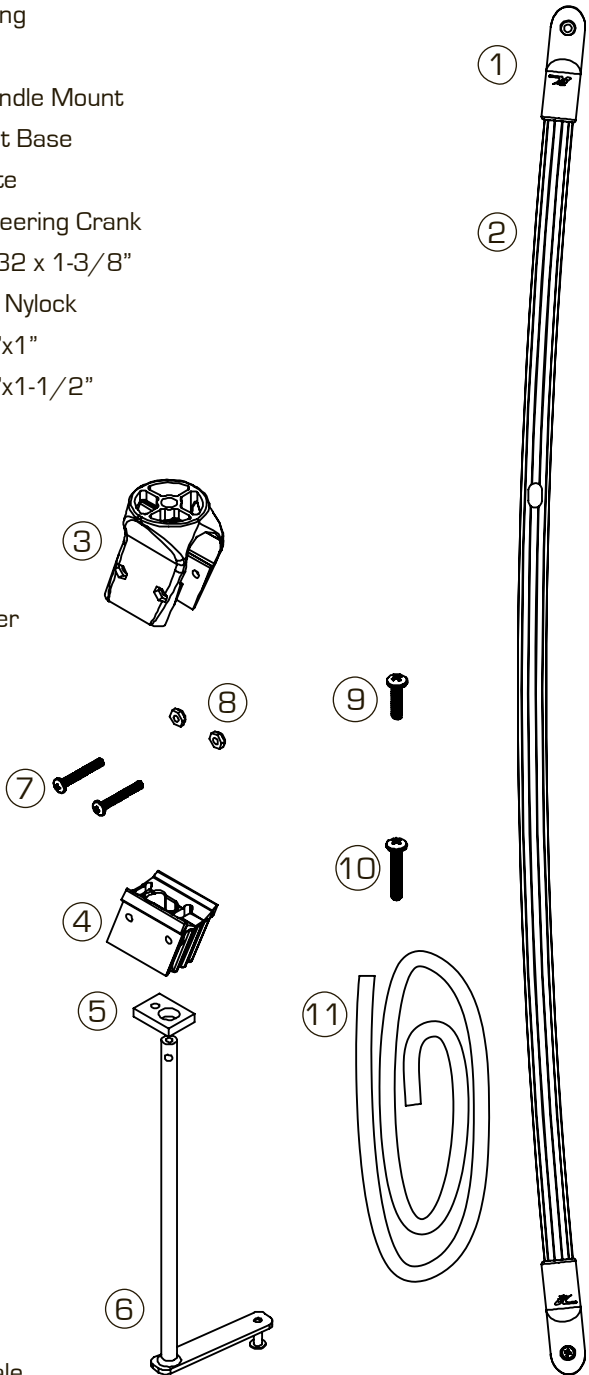

Items not shown to scale

Installation

Video available at:

www.hobiecat.com/support/h-rail/

①

Loosen the BOA Rudder Line Tensioner by pulling the knob away from the hull.

BOA Rudder Line Tensioner Included on 2014 or newer models.

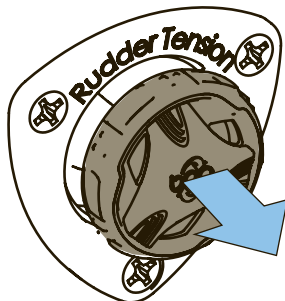

②

Remove the Hobie sticker from the top of the steering handle. Using a 1/8" Allen, remove the steering handle and crank pin. Remove old steering crank. Keep all hardware for later use.

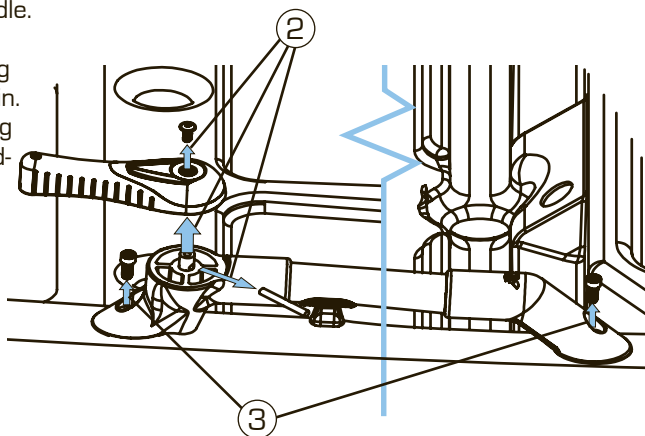

③

Using a 1/4" allen key, remove the old rail and mounts.

④

Place the H-Rail mount base on the gunwale and insert the crank from the top to align the base to the old hole. Center the base and drill a 1/4" hole using the rear hole of the base as a guide.

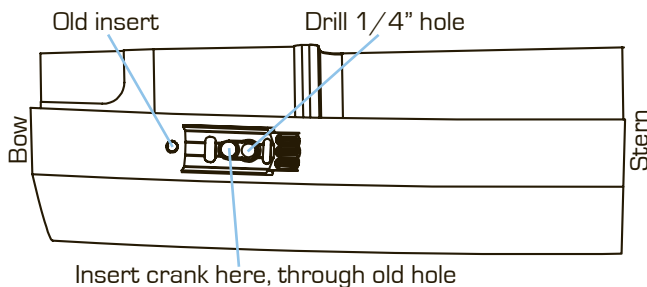

⑤

Remove crank from mount base and pass included rope through the crank hole and into the hull.

⑥

Pass the rope through the large hole of the backing plate and tie a knot.

⑦

Pull the rope from the top and align the threaded hole in the backing plate hole to the 1/4" hole that was just drilled.

⑧

Using the rope to hold the backing plate in position, screw the 1/4"x1-1/2" screw into the plate. Do not tighten the screw all the way yet.

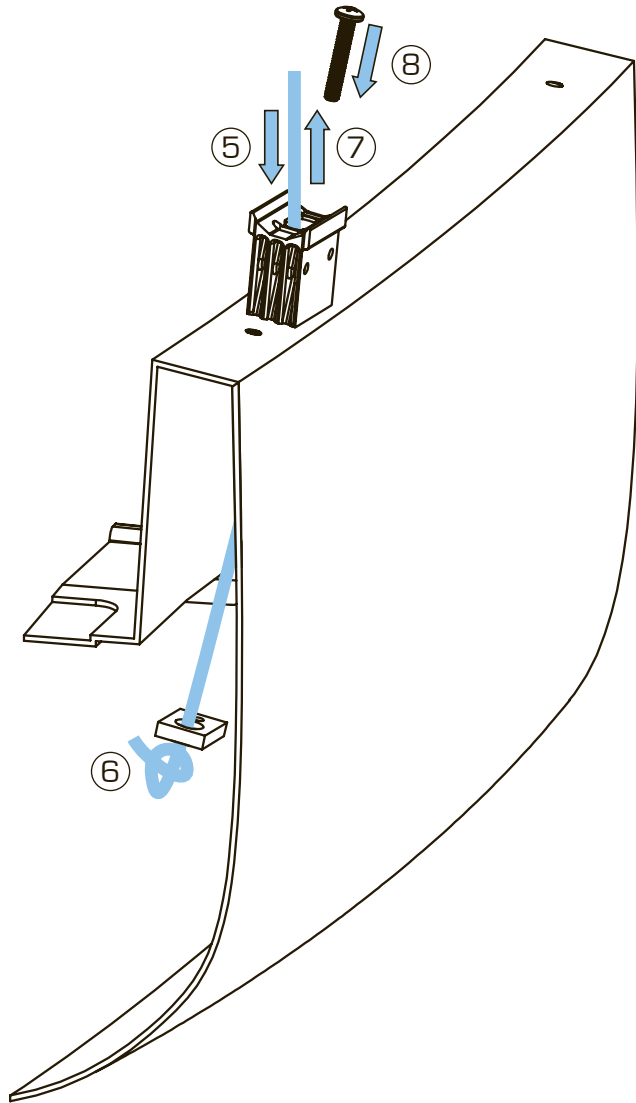

9

Slide the spring from the old crank onto the new longer crank. Insert the new longer crank up through the slot in the plastic support, backing plate and rail mount. Insert the pin to hold the steering crank.

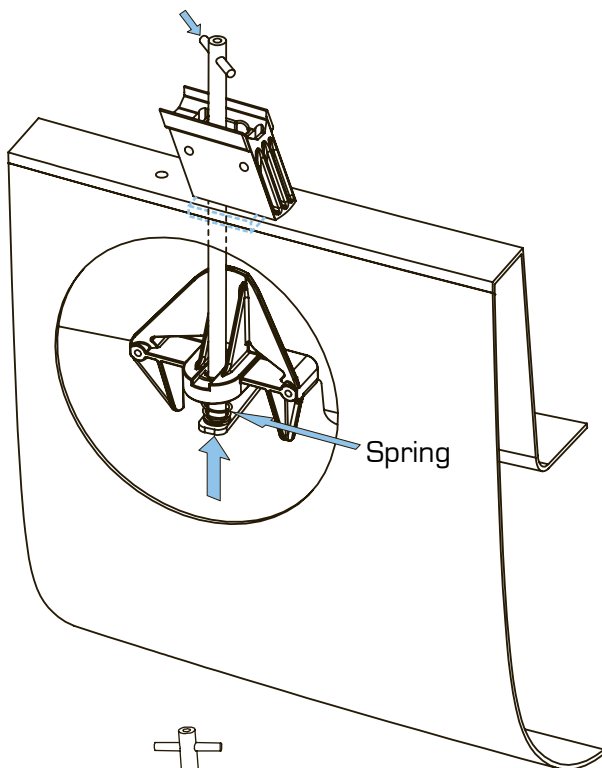

10

Tighten the screw holding the backing plate in place.

11

Attach the steering line loops that were removed from the old crank over the rivet at the end of the new steering crank. This may require the steering lines to be loosened under the steering cover at the rear of the boat.

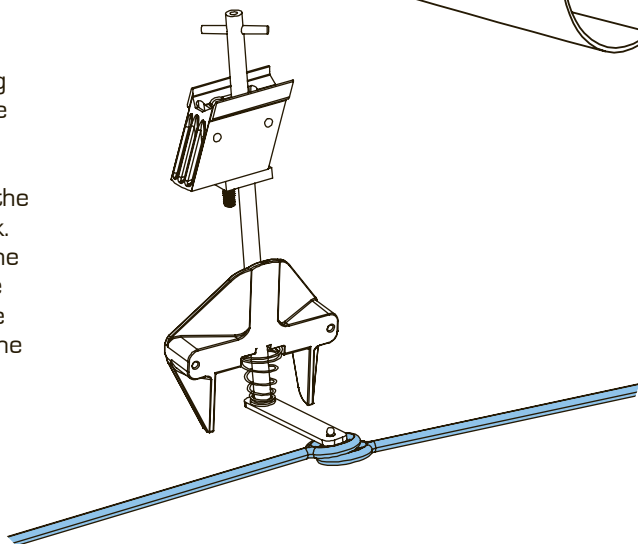

12

Insert the rail into the tall end fittings. Align the fittings. Align the  logo on top of the fittings with the slot in the rail.



13

Orient the steering mount to match the direction of the base mount. Slide the steering mount over the rail a few inches behind the slot.

14

Remove the pin from the steering crank and allow it to fall below top of rail.

15

Insert the 5/16-18 cap screw from the rear of the old rail fitting into the rear end fitting.

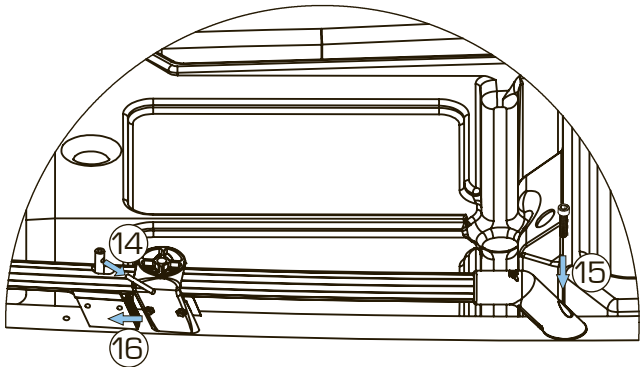

16

Slide the steering mount over the rail base mount.

17

Push the steering crank up through the steering mount and insert the pin so it is centered on the mount.

18

Use the included 10-32x1-3/8" screws and nylock nuts to secure the mount.

19

Install the steering handle and button head screw and sticker.

20

Secure the front end fitting of the rail using the 1/4-20x1" pan head screw. You may need to flex the rail to install the screw.

21

Repeat steps 1-20 on the other side.

22

Tighten and adjust steering according to manual.

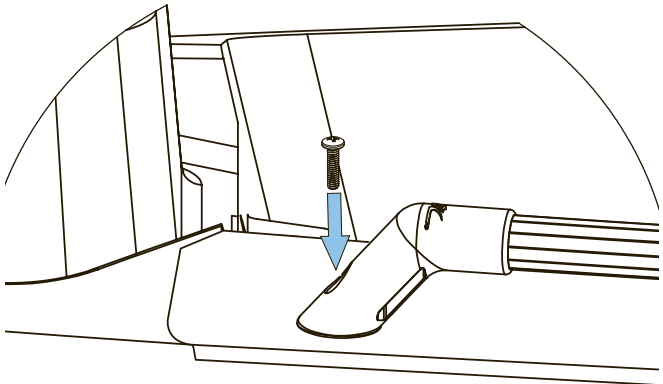
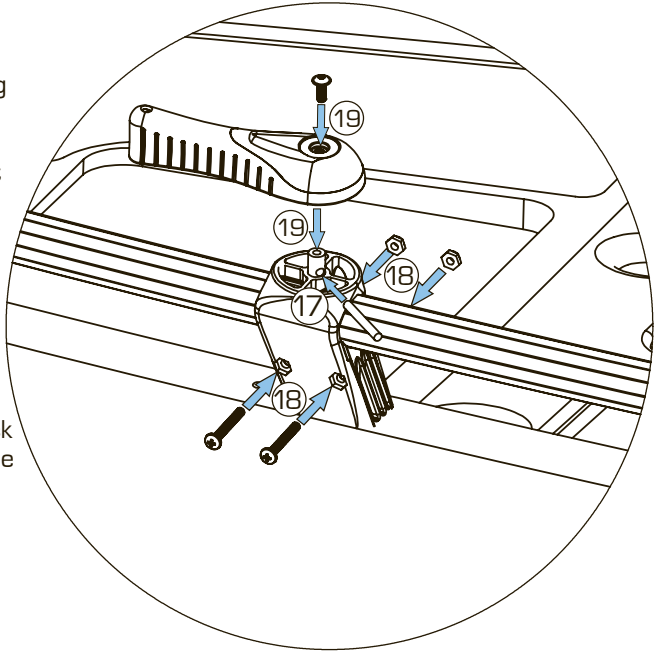

Hobie Cat Company
Holding Company
Oceanside, California, USA
1-800-Hobie-49
hobiecat.com

Hobie Cat Australasia
Subsidiary
Huskisson, New South Wales Australia
1-800-4-Hobie
hobiecat.com.au

Hobie Cat Europe
Subsidiary
Toulon, France
+33 (0) 494 08 78 78
hobie-cat.net

Hobie Kayak Europe
Independent Distributor
Stellendam, The Netherlands
+31 (0) 187 499 440
hobie-kayak.com

Hobie Cat Brasil
Independent Distributor
Porto Belo, Santa Catarina, Brasil
+55 (73) 3369-6096
hobiecat.com.br



PN 84625314
PN 84625312
REV 151027